

Genu-Flip™ Assembly Instructions

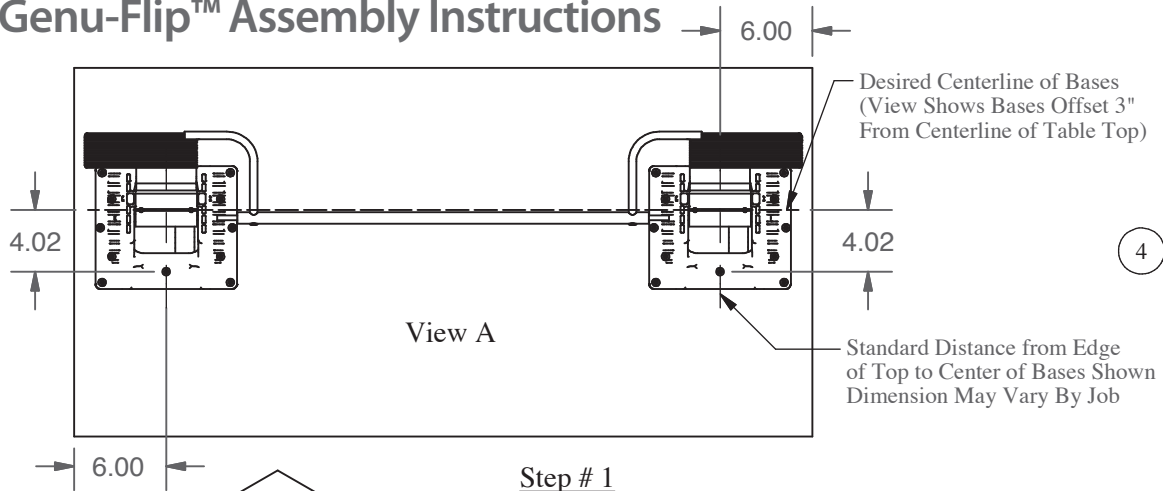

View A

Step # 1
Position Top Upside Down On Carpet or Other Non-abrasive Surface.

Step # 2
If Top Not Pre-drilled, Mark and Drill Two Ø1/8 Pilot Holes 1/2" Deep at the Locations Shown In View A.

Step # 3
Verify that the Pivot Block In Both Genu-Flip Assemblies Are Positioned As Shown Below. If Not, Press the Genu-Flip Handle Down to Allow the Block to Pivot and Rotate the Block to This Position.

Step # 4
Place the LH Genu-Flip Assembly (#1) Onto the Top at Desired Location and Attach It to the Top with One #12 Screw (#4) as Shown in View B.

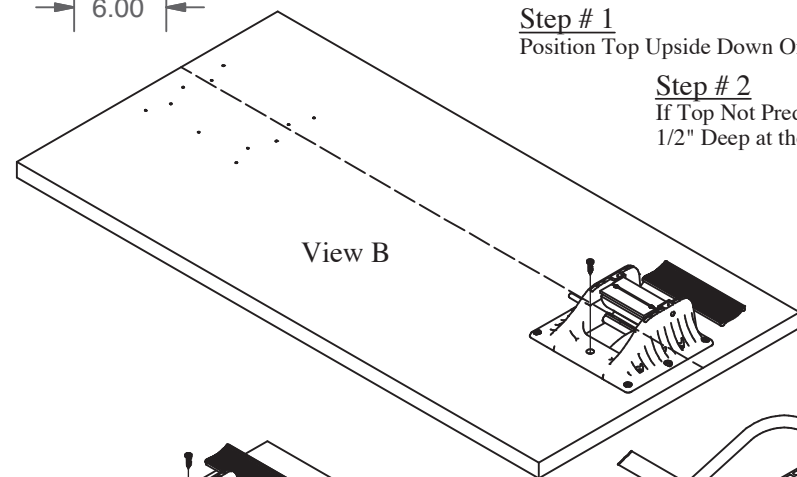

View B

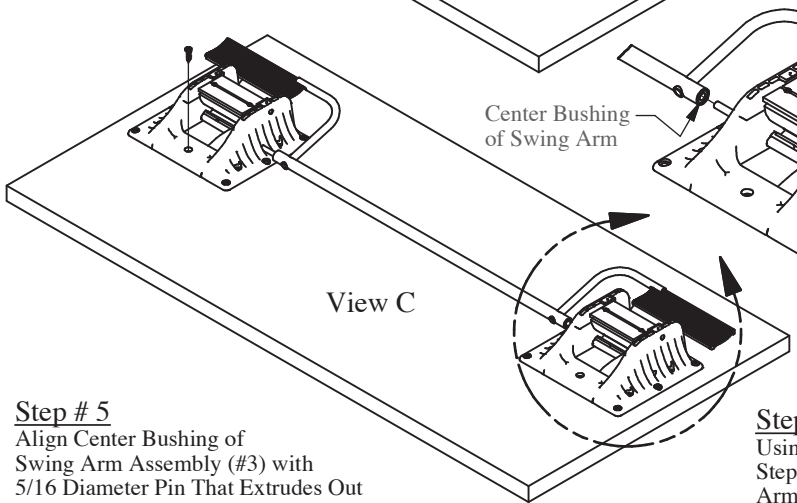

View C

Step # 5
Align Center Bushing of Swing Arm Assembly (#3) with 5/16 Diameter Pin That Extrudes Out From the LH Genu-Flip Assembly (#1) and Align the Center of Formed Tube on Swing Arm Assembly with the the Rounded Profile of the Handle. Slide Swing Arm Assembly Onto the LH Genu-Flip Assembly Until the End Of Bushing Is Flush With the Edge of Genu-Flip Housing.

Step # 6
Using the Same Method as Step #5, Align the RH Genu-Flip Assembly (#2) with the Other End of the Swing Arm Assembly (#3). Slide the RH Genu-Flip Assembly Into Swing Arm Assembly Until the Pilot Hole in the Top Lines Up With the Hole In the Genu-Flip Housing as Shown In View C. Install a #12 Screw (#4) to Secure Genu-Flip to Top.

Step # 7
Verify That the Two Genu-Flip Assemblies Are Inline with Each Other.

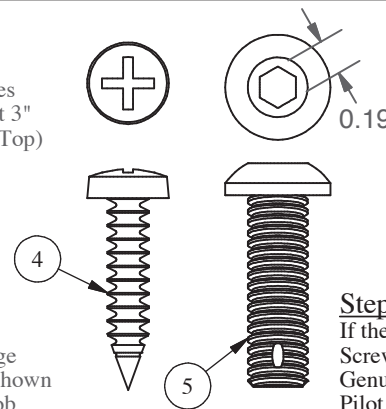

Parts List		
Seq	Qty	Description
1	1	Genu-Flip Assembly LH
2	1	Genu-Flip Assembly RH
3	1	Genu-Flip Swing Arm Assembly
4	22	Screw #12 X 1 PPH
5	4	Screw 5/16-18 X 1 BHCS
6	2	End Base Assembly

Step # 8
If the Top Was Pre-drilled, Install the Remaining #12 Screws (#4). If the Top Was Not Pre-drilled, Use the Genu-Flip Housing as a Template and Drill Ø1/8 Pilot Holes By 1/2" Deep Before Installing the Remaining Screws.

Step # 9
If Not Already Pre-Assembled, Assemble the End Bases Per the Base Assembly Instructions.

Step # 10
Align the Two Thru Holes In One of the End Base Mounting Plates With the Two Tapped Holes In the Genu-Flip Pivot Block. Hand Start a 5/16-18 Screw (#5) Thru the Mounting Plate and Into Each Tapped Hole. Then, Using a 3/16" Hex Driver, Tighten Each 5/16-18 Screw To Between 20 and 25 Foot Pounds. Repeat Process for Each Base.

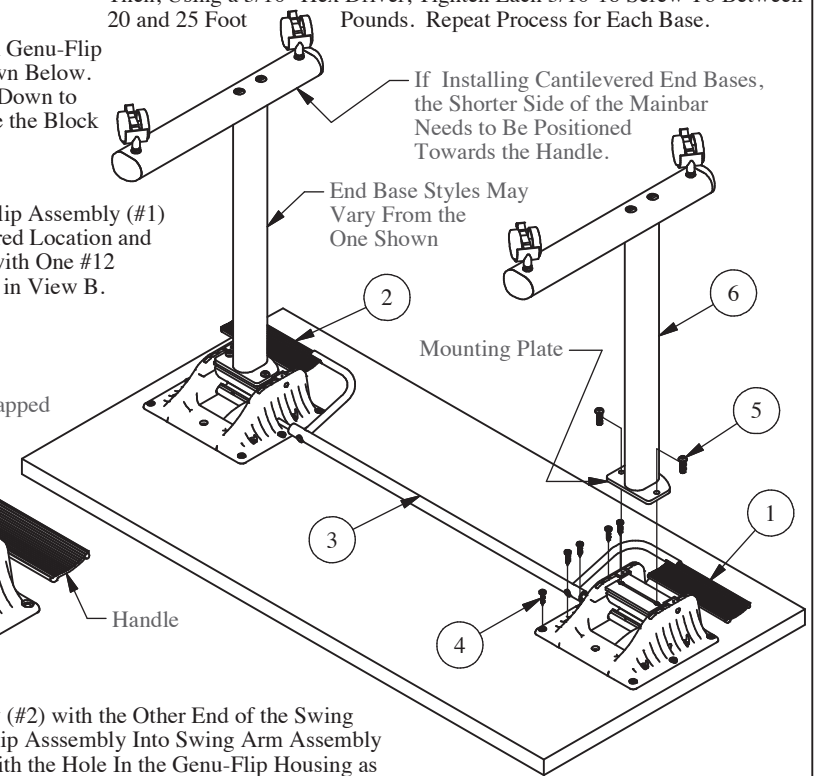

www.smartdesks.com

800 770 7042