

MiraVista™

ASSEMBLY INSTRUCTIONS



For technical support, please
contact SMARTdesks:

800-770-7042



Scan QR Code with smartphone for
instant response.



shaping conferencing & educationsm

SMARTdesks®

www.smartdesks.com

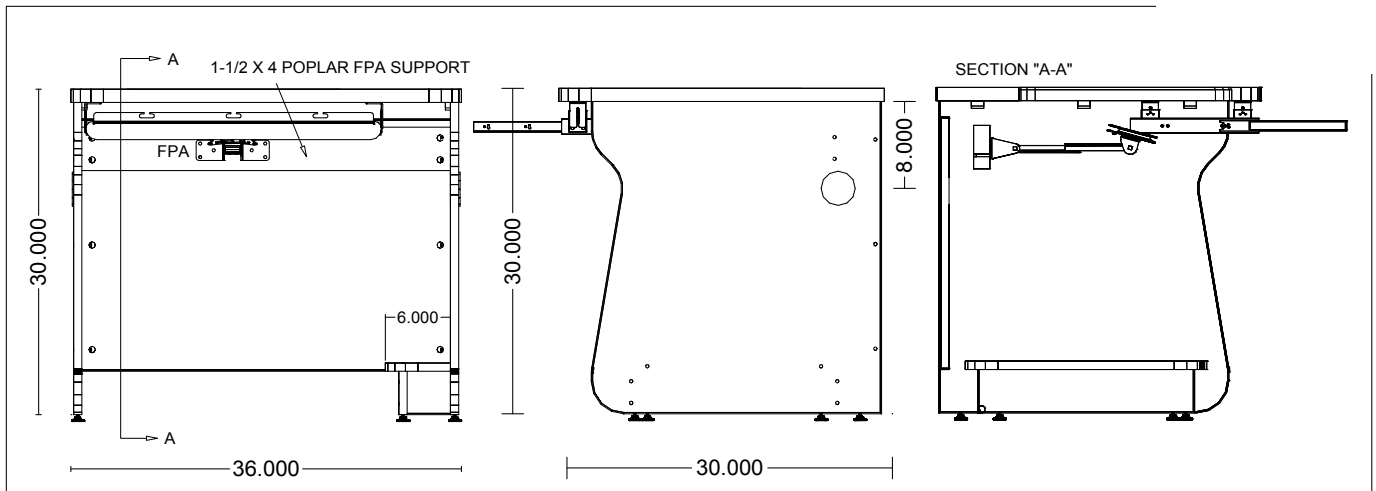

Single MiraVista Computer Desk SMV-363030-TKF

These top and side view drawings should help with parts identification. Section A-A shows the spatial location of the poplar hardwood support beam for the FPA Flat Panel Arm, keyboard tray and CPU stage.

MiraVista™ is assembled with pins and cams using a Phillip's #2 driver.

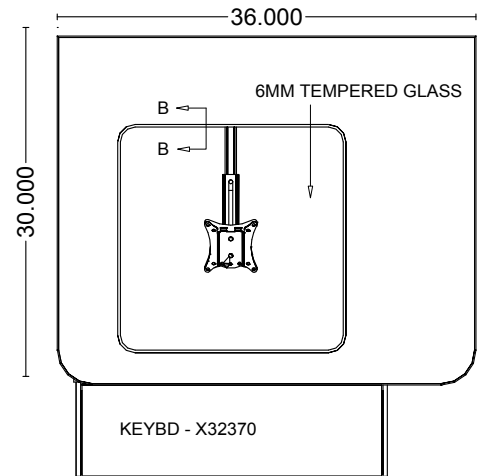

Note the locations of the side panel wire grommets and the wire management J channels, which are mounted flush with the bottoms of the modesty panels. Power outlet strips are mounted on the modesty panels, above the J channel wire management troughs.

Pilot holes are provided for the mounting of keyboard trays, using 1/2" #8 thread Phillip's drive wood screws.

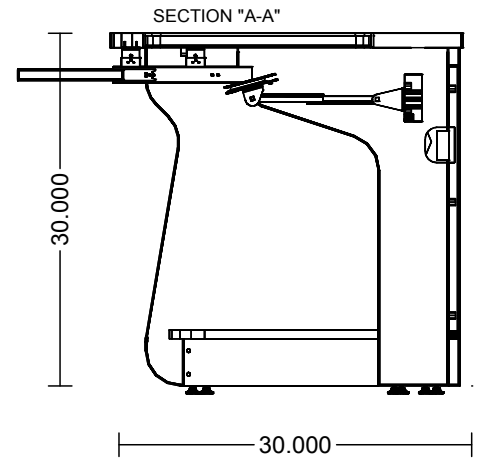
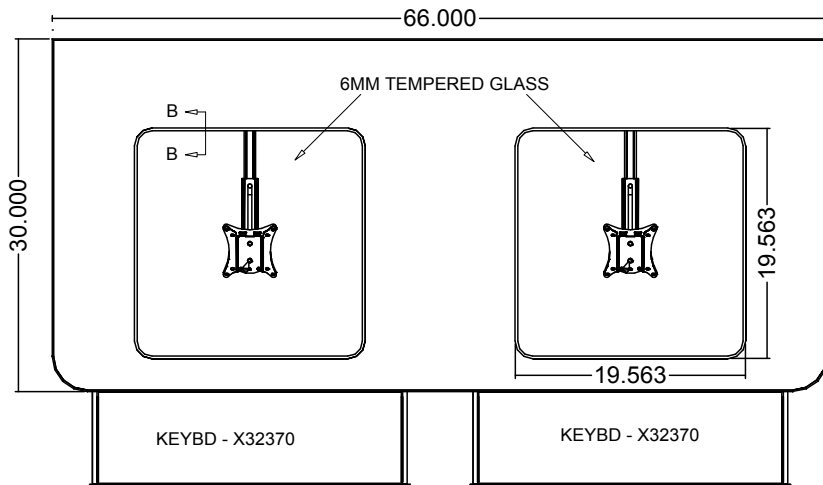
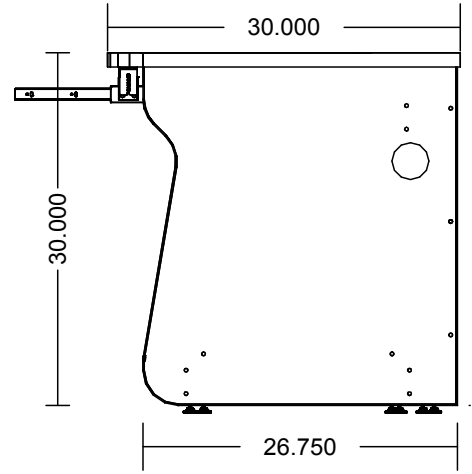
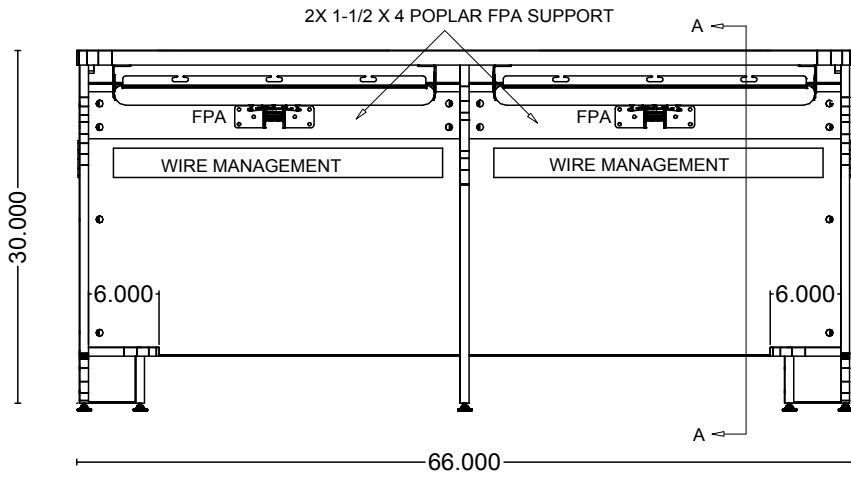

Assembly approach:

On a carpet or furniture blanket, place the desktop on the floor face down.

Install the side panels to the top, pushing the plastic fittings into the holes provided. Tighten set screws (#2 Phillips) to lock the pieces together. Do not overtighten.



These plastic fittings come apart, install in the sides and top with the screw part in the sides. Capture the fittings and tighten the screw.

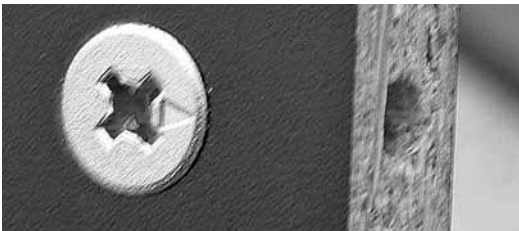

On the modesty panel, align the cam arrows with the holes, then insert the pins and tighten with a #2 Phillips driver.

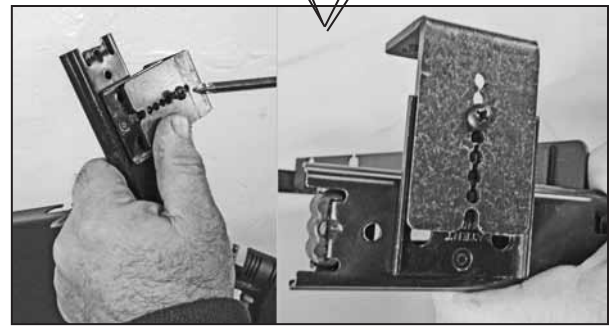
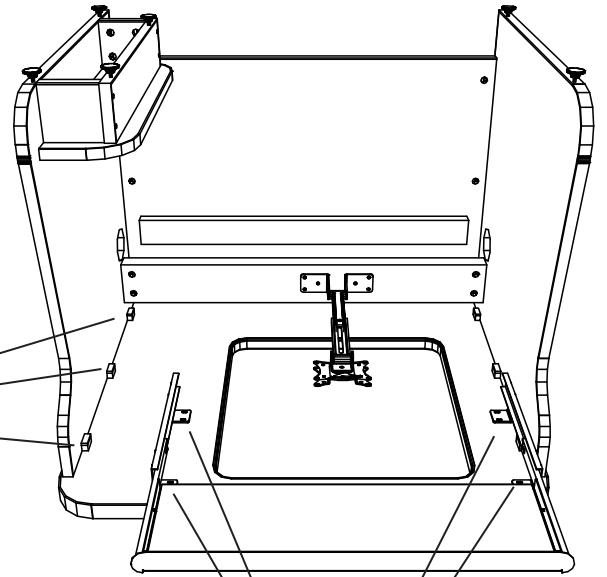

Assemble tabs to the keyboard trays tabs in. Use the third hole from the bend and see if this fits your keyboard. Install the keyboard tray with 1/2" #8 thread wood screws.

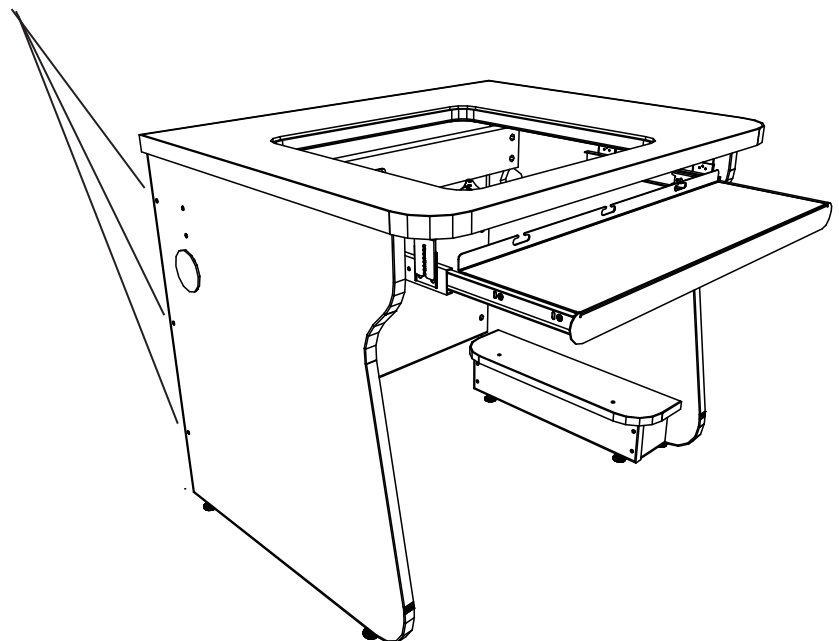
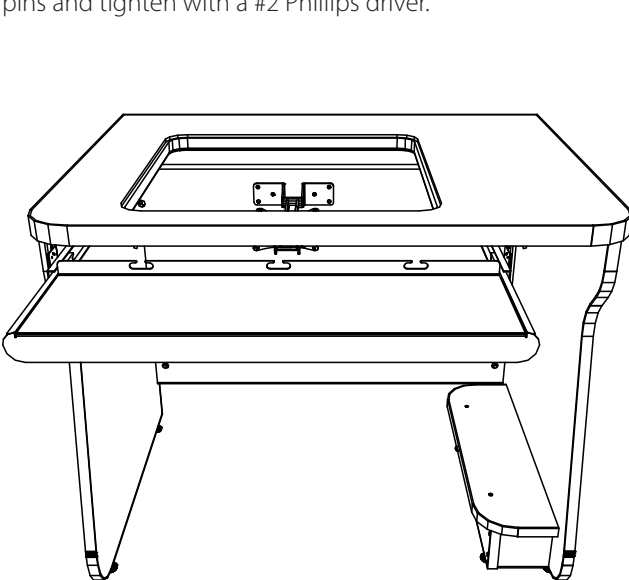

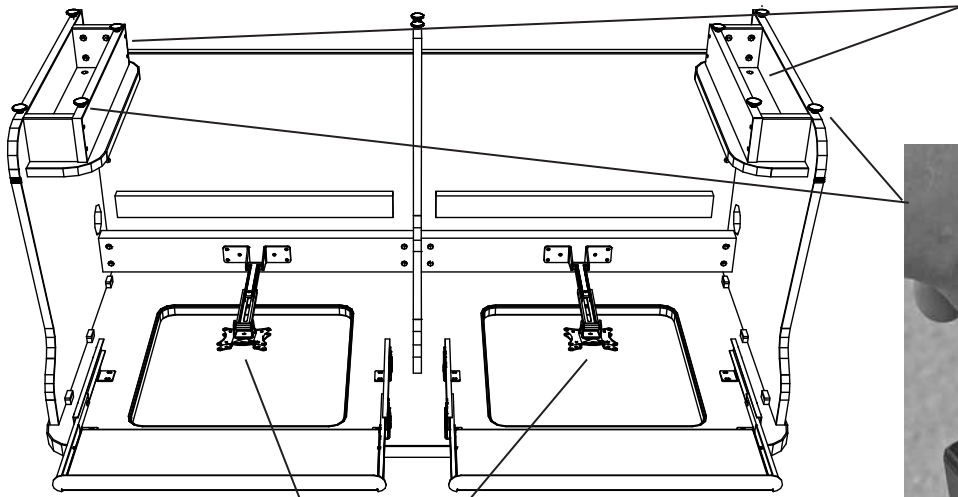

Make a sub assembly of the CPU stages, assembling with pins and cams, then install to side panels with pins and cams.



Spin in the floor glides all the way, then see if you need to make adjustments when the desk is installed in its final position.



Sub assemble the Flat Panel Arm to the hardwood board that serves as a support beam. Install with wood screws. Install the assembly to the desk sides and center panel with pins and cams.

The VESA mount is universal for installation of LCD monitors at 100mm or 75mm mounting hole locations using your monitor's mounting screws.



The double desk has a center support panel which installs with pins and cams. The FPA arm supports are installed into it using double-ended pins. For this reason, you need to assemble the arm supports together with the center support and install this as one piece into the modesty panel, top and sides.

Turn unit over and place it on its feet.

Place plate glass into viewing frame.

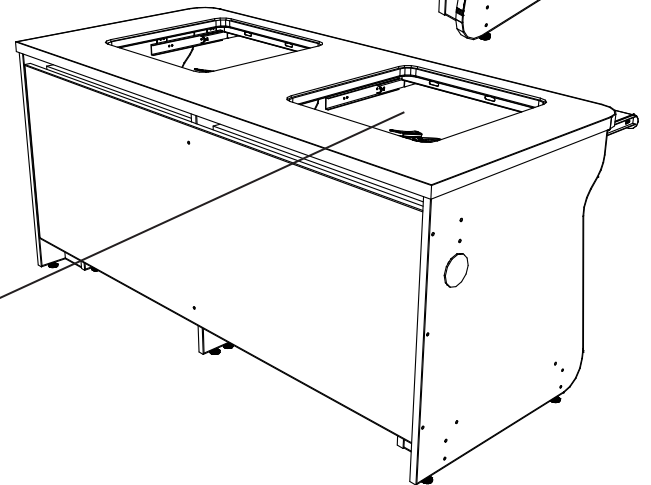
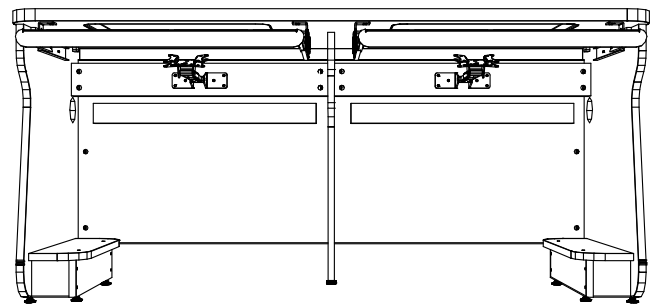

For technical support, please
contact SMARTdesks:

800-770-7042



Scan QR Code with smartphone for
instant response.

shaping conferencing & educationsm



www.smartdesks.com